

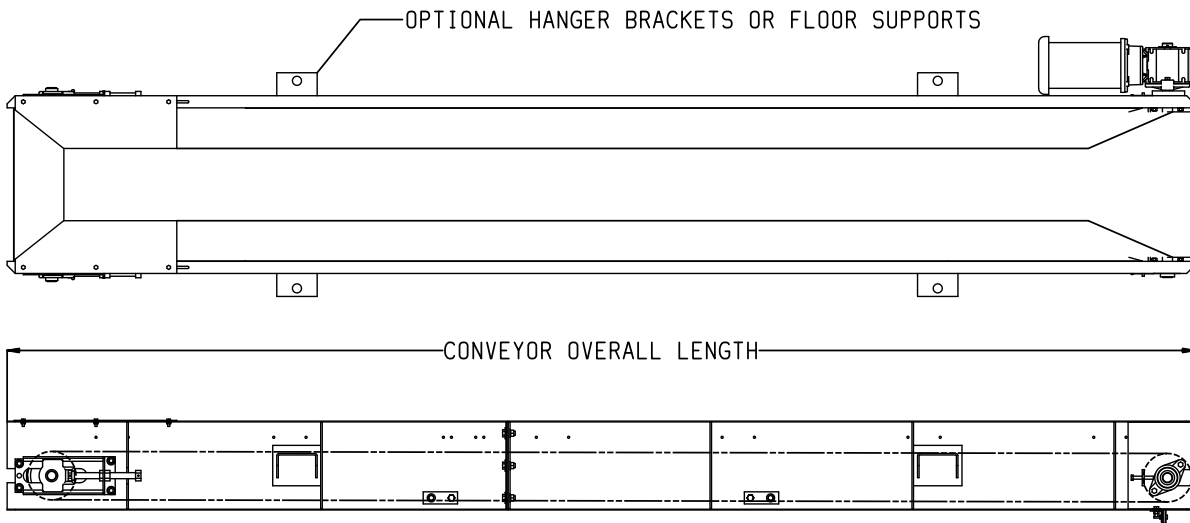

# Trough Belted and Transfer Conveyors

Bunting® offers a full line of **Trough-Belted and Transfer Conveyors for Plastic, Rubber, Wood, Electronic, Construction and Municipal Recycling ground and pelleted materials.**

Bunting® is the expert to layout your system – whether you are re-grinding in house scrap product or designing a complete recycling facility. These conveyors can vary from 2' to 200' long with belt widths of 12" to 60" wide.



## Specifications:

Width	12" - 60"
Length	Must be greater than the width
Pulley	4" or 6" High Intensity NEO
Floor Supports	As needed
Belt	Available in either SBR standard cleat top or smooth
Sideguards	Standard - 3" tall
Construction	Formed 12 gage or 3/16" steel
Controls	None standard - recommend variable speed controller
Belt Speed	Best results below 30-300 FPM

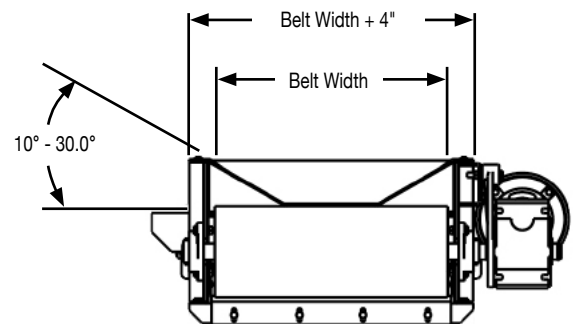

## Model Numbering:

GFC XX-XXX  
 Belt Width →      ← Conveyor Length