

# Magnetic Crossbelt Conveyor

Bunting® Magnetics Co. offers the most respected Magnetic Crossbelt Separation Conveyor in the Recycling Industry to maximize product purity. Its distinct design amplifies magnetic strength and reachout for effective metal removal whether mounted at the end of a conveyor or over the belt mid-stream. The all-stainless steel frame minimizes ferrous scrap from sticking to the side frames while the UHMW belt support wings prevents the metal from sticking in between the belt and magnet.

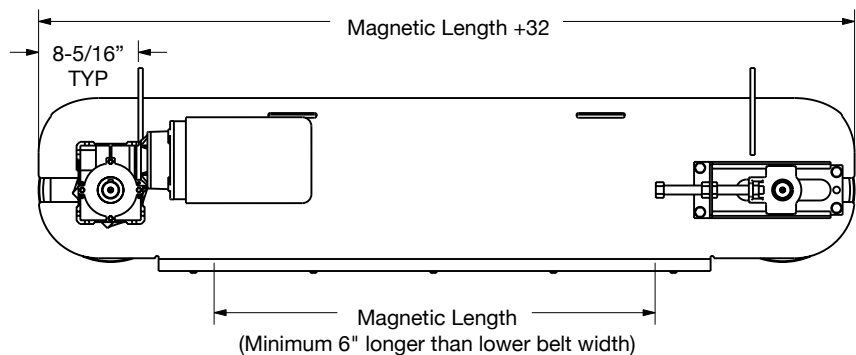

## Specifications:

Width	16", 24", 30" and 36"
Length	Based on application
Pulley	12" Diameter
Floor Supports	As needed
Belt	2 and 4-ply SBR with 2" cleats
Construction	Standard - Stainless Steel 1/4" Frame
Belt Speed	Best results below 275 FPM

## Model Numbering:

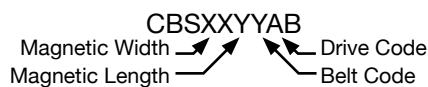

### Belt Code:

- Type A-#53, 2-ply with 2" tall cleats on 24" C/C
- Type B-#53A, 4-ply with 2" tall cleats on 24" C/C
- Type Z - Special belt type, cleat size, or cleat spacing

### Drive Code:

- A - 230/460VAC, 3PH, 60HZ
- B - 115/230VAC, 3PH, 60HZ
- Z - Special motor, must specify

Belt Speed: 275 FPM

